

CAD FILE:

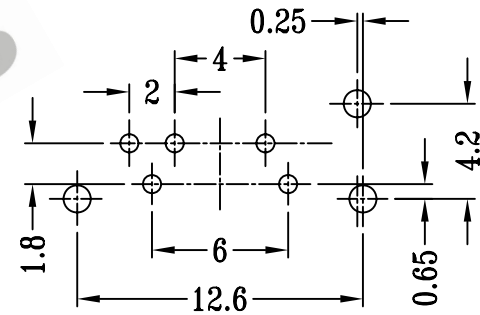
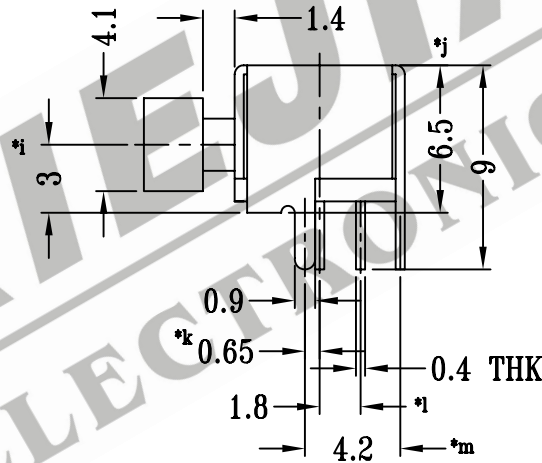
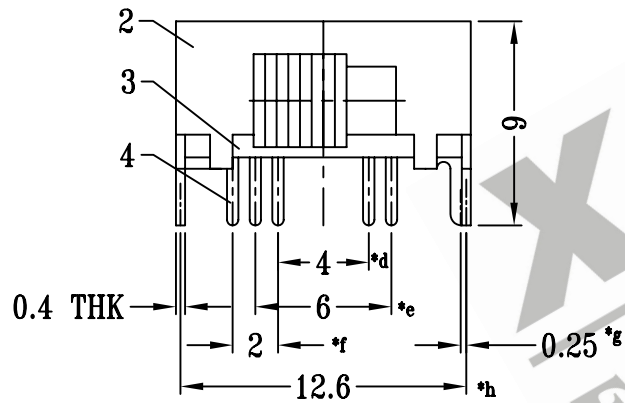
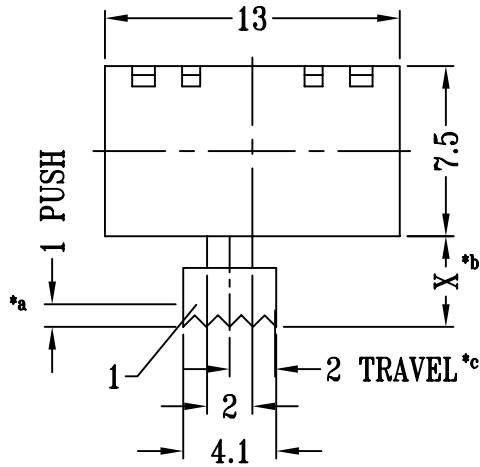

SCHEMATIC (NON-SHORTING)

P.C.B LAYOUT

NO.	PART NAME	MATERIAL	Q'TY	FINISHING
10	SLIDER	POM	1	BLACK
9	STEEL BALL	STEEL	3	NATURAL
8	SCREEN	STAINLESS STEEL	1	NATURAL
7	CONTACT	PBS STRIP	1	Ag PLATED
6	SPRING	STAINLESS STEEL	3	TEMPER
5	CONTACT CLIP	PBS	1	Ag CLAD
4	TERMINAL	BRASS STRIP	5	Au PLATED
3	BASE	PHENOLIC RESIN	1	NATURAL
2	FRAME	STEEL STRIP	1	Ni PLATED
1	KNOB	PC	1	BLACK

注:带"*"表示关键尺寸(13个)

TOLERANCE UNLESS SPECIFIED		SHENZHEN XIEJIA ELECTRONICS CO.,LTD.			
WITHIN: 1.5±0.1mm		ISSUE	DATE	DESCRIPTIONS	
OVER : 1.5±0.2mm				APPD.	
TITLE : PUSH SWITCH		UNIT : MM	DRWG NO.: XJ-DR-PS11BSK13D01-00		
MODEL: PS-11B-SK-13D01		SCALE: 3:1	DWN.	ZHOUYU	2002-10-8
ALL MATERIALS MUST BE COMPLIANT TO ROHS			CHK'D	FANGYING	2002-10-8
			APPD.	KANGXINAN	2002-10-8